

# CUSTOMER'S APPROVAL SHEET

CUSTOMER	APPROVED		
SUPPLIER	DRAWN	CHECK	APPROV.

深圳市凯莱锐电子科技有限公司



# Contents

1. Feature
2. Cautions
3. Specification
4. Connector
5. Block Diagram
6. Protocol
7. Command List
8. OSD Menu
9. Drawing

深圳市凯莱锐电子科技有限公司

**Feature**

- **1/2" Sony CMOS sensor**  
2.17M Pixels(Total) / 2.12M Pixels(Active)
- **Full HD Resolution**  
1920x1080p 60(50)/30(25)fps  
1920x1080i 60(50)fps  
1280x720p 60(50)/30(25)fps
- **DAY & NIGHT**  
This camera supports filter changed day and night function using DC Motor controller. It can be changeable OLPF day to night depending on the luminance level using DC Motor. It can be also controlled by external Day and Night port.
- **WDR (Wide Dynamic Range)**  
WDR, more effectively than previous models,  
by applying an optimum fusion ratio when combining the high speed shutter used in bright areas and the low speed shutter used in dark areas.
  - Dual shutter image fusion (Max. 90dB)
  - Line by Line WDR (Max. 120dB)
- **DNR (Digital Noise Reduction, 2D+3D)**  
The DNR technology eliminates noise thus generating a distinct and clear image. This camera DNR function utilizes both an adaptive 2D filter reducing noise in the brightness of the image and an adaptive 3D filter reducing noise caused by movement.
- **Privacy mask Function**  
The privacy zone function makes it possible to make specific areas of the scene from view.
- **On Screen Display**  
This camera supports the OSD function. And so, the camera can be controlled by selecting text displayed on the monitor screen.
- **Intelligent motion detection**  
You can transmits an alert signal when it detects motion of an object on the screen. This feature is useful when you have to monitor several screens simultaneously.

- **Output**

Digital output : EX-SDI

Analog output : HD-Analog, CVBS(※ Test Only)

- **Protocol**

This camera supports the multi-protocol (VISCA, PELCO-D, PELCO-P)

深圳市凯莱锐电子科技有限公司

Cautions**• Power Supply**

This camera must always be operated a DC 12V

**• Handling of the unit**

Be careful not to spill water or other liquids on the unit.

**• Operating and storage location**

Avoid viewing a very bright object (such as light fittings) during an extended period. Avoid operating or storing the unit in the following locations.

- Extremely hot or cold places (operating temperature  $-10\text{ }^{\circ}\text{C} \sim 50\text{ }^{\circ}\text{C}$ , however, we recommend that the unit be used within a temperature range of  $0\text{ }^{\circ}\text{C} \sim 45\text{ }^{\circ}\text{C}$ )
- Damp or dust place
- Places exposed to rain
- Places subject to strong vibration
- Close to generators of powerful electromagnetic radiation such as radio or TV transmitters.

**• Handling of the Unit**

- Remove dust or dirt on the surface of the CMOS sensor with a blower.
- Avoid the use of volatile solvents such as thinners, alcohol, benzene and insecticides. They may damage the surface finish and/or impair the operation of the camera.

深圳市凯莱锐电子科技有限公司

## Specification

Model	CM8200-385
Image Sensor	1/2" Sony IMX385LQR-C CMOS Sensor
Total Pixels	1952(H) x 1113(V) = 2.17M pixels
Effective pixels	1945(H) x 1097(V) = 2.13M pixels
Active pixels	1937(H) x 1097(V) = 2.12M pixels
Scanning system	Progressive Scan
Sync. System	Internal
Resolution	Digital : 1080p 60(50)/30(25)fps, 1080i 60(50)fps, 720p 60(50)/30(25)fps Analog : HD-Analog (1080p 30(25)fps, 1080i 60(50)fps, 720p 60(50)/30(25)fps) CVBS (700TVL)
Min. illumination (50%)	Color(1/30s, 77.7dB) : 0.01 lux , BW(1/30s, 77.7dB) : 0.002lux Color DSS(1/1s, 77.7dB) : 0.001 lux , BW DSS(1/1s, 77.7dB) : 0.0002 lux
Video Output	Digital : EX-SDI Analog : HD-Analog / CVBS(※ Test Only)
S/N Ratio	more than 50dB (AGC off)
Function	
Zoom/Focus	
Focus Mode	Auto / Manual
Scanning	Half / Full
One Shot	On <sup>d</sup>
Sync TDN	Off / On
Lens Refresh	On <sup>d</sup>
Refocus	Off / 1day ~ 10days
Exposure	
Lens Mode	Indoor / Outdoor / Deblur
Brightness	0 ~ 20 steps
Shutter	Auto / Manual ( 1/30(1/25) ~ 1/60000 )
DSS(Digital Slow Shutter)	Off / x2 / x4 / x8 / x16 / x32 (/x64 : 60 or 50 fps mode only)
AGC(Gain Control)	0 ~ 10 steps
Flickerless	Off / On
WDR/BLC	Off / WDR(Line/Frame) / BLC
Day&Night	Auto / Day / Night / Ext-in
White Balance	
Mode	Auto / One Push / Manual / Indoor / Outdoor / Auto-Ext
Red Gain	0 ~ 20 steps (Manual mode only)
Blue Gain	0 ~ 20 steps (Manual mode only)
Chroma	0 ~ 20 steps
Image	
HLC	Off / On / Night only
DNR	Off / Low / Middle / High / Auto
Mirror	Off / H / V / H&V
Sharpness	0 ~ 10 steps
ACE	Off / Low / Middle / High
Defog	Off / On(Auto / Manual)
Freeze	Off / On
Gamma	0.45 / 0.55 / 0.65 / 0.75
E.Zoom	Off / On (x2 ~ x32)

## Specification

Model	CM8200-385
Intelligence	
Privacy Mask	Off / On (24 points)
Motion Detection	Off / On (3 points)
Special Function	
Defect DET	Off / On
Image Range	Full / Comp. / User (0 ~ 32 steps)
System	NTSC / PAL
HD Format	1080i60(50)fps / 1080p60(50)fps / 1080p30(25)fps / 720p30(25)fps / 720p60(50)fps
SDI Mode	Off / HD-SDI / EX-SDI 135M / EX-SDI 135M+ / EX-SDI 270
HD-Analog	Off / CVBS / HD-T
Comm	ID : 1 ~ 255
	Baud Rate : 2400 / 4800 / 9600 / 19200 / 38400 / 57600 / 115200 bps
	Protocol : Pelco-P / Pelco-D / VISCA / Update
	UTC : On / Off
Display	
Disp Sel (Off / On)	ID / Title / Zoom Ratio / System Message
Set Title	Text Edit
Init Sel (Off / On)	ID / Baud Rate / Protocol / Version / Init. Message
Set Init Msg	Text Edit
Language	English / Simplified Chinese / Traditional Chinese / Japanese
Electrical	
Power Source	DC12V±10%
Power Consumption	280mA
General	
Power Input	Connector
Video Output (SDI)	MMCX Connector
Operating Temperature	-10°C ~ +50°C (Humidity : 0%RH ~ 80%RH)
Storage Temperature	-20°C ~ +60°C (Humidity : 0%RH ~ 90%RH)
Dimension (H x V x T)	42mm X 42mm X 1.2mm

深圳市凯莱锐电子科技有限公司

**Connector**

Top View

Bottom View

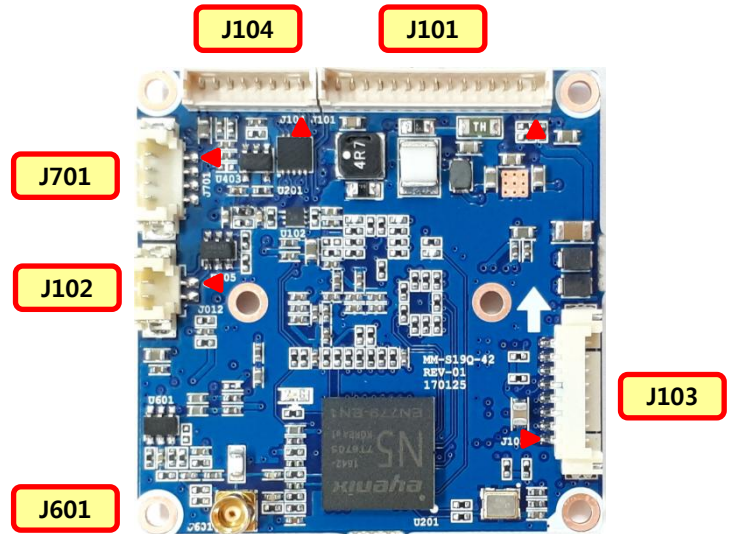
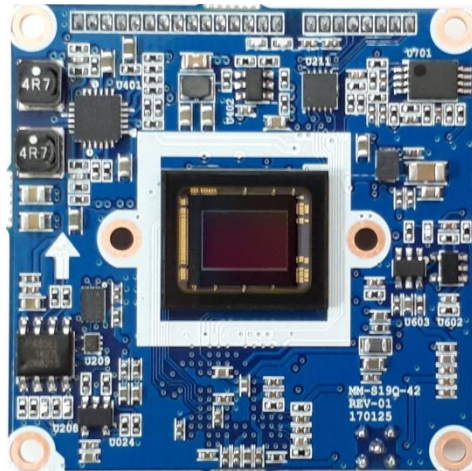

1. J101 : I/O Connector

Pin NO	Pin Name	Description	Normal	Active	I/O
1	DC+12V	DC+12V Input			I
2	GND	Board Ground			-
3	VBS	Composite Video Output			O
4	SDI_SEL	SDI Select			-
5	GND	Board Ground			-
6	GPIO	Optional			O
7	ADKEY	OSD Control			I
8	GND	Board Ground			-
9	IR_ON	IR Lamp Control	0V	+3.3V	O
10	D/N_IN	Day & Night Control Input	+3.3V	0V	I
11	CDS_IN	CDS Input			I/O
12	MD_OUT	Motion Detection output			O
13	GND	Board Ground			-
14	485(+)	RS-485 Data+			I/O
15	485(-)	RS-485 Data-			I/O

Molex : 53047-1510



## 2. J601 : HD-SDI Connector

Pin NO	Pin Name	Description	Normal	Active	I/O
1	SDO	EX-SDI Output			O
2	GND	Board Ground			-
Linkwork : MMCX-130100A					

## 3. J103 : Connector for upgrading Camera Program

Pin NO	Pin Name	Description	Normal	Active	I/O
1	RSTN	JTAG Upgrade Mode Setting			-
2	SFCSN	JTAG Upgrade Chip Selector			-
3	SFDQ0	JTAG Upgrade Data1			-
4	SFDQ1	JTAG Upgrade Data2			-
5	SFCKO	JTAG Upgrade Clock			-
6	GND	Board Ground			-
7	RXD	UART (Rxd)			-
8	TXD	UART (Txd)			O
Yeonho Electronics : 12505WR-08					

## 4. J102 : Day &amp; Night Motor Control Connector

Pin NO	Pin Name	Description	Normal	Active	I/O
1	CONT(+)	Day & Night Motor Drive + Output	Open	4.5/0V	O
2	CONT(-)	Day & Night Motor Drive - Output	Open	0/4.5V	O
Yeonho Electronics : 12505WS-02					

## 5. J701 : Auto Iris Lens Control Connector

Pin NO	Pin Name	Description	Normal	Active	I/O
1	DMP+	DC Iris Damping Motor +	DAMP+		O
2	DMP-	DC Iris Damping Motor -	DAMP-		O
3	DRV+	DC Iris Motor Drive	DRIVE+		O
4	GND	Board Ground	DRIVE-		-
Yeonho Electronics : 12505WS-04					

**6. J104 : Motorized Lens Control Connector**

Pin NO	Pin Name	Description	Normal	Active	I/O
1	Zoom A+	Motorized Lens Zoom A+ Signal			O
2	Zoom A-	Motorized Lens Zoom A- Signal			O
3	Focus A+	Motorized Lens Focus A+ Signal			O
4	Focus A-	Motorized Lens Focus A- Signal			O
5	Focus B+	Motorized Lens Focus B+ Signal			O
6	Focus B-	Motorized Lens Focus B- Signal			O
7	Zoom B+	Motorized Lens Zoom B+ Signal			O
8	Zoom B-	Motorized Lens Zoom B- Signal			O
<b>Molex : 53047-0810</b>					

深圳市凯莱锐电子科技有限公司

**Connector**

**1. D&N IN (J101-10)**

Port giving input of any external signal in Day&Night “Ext-In” Mode

- Day Mode : Open
- Night Mode : Low (Ground)

**2. AD KEY (J101-7)**

The external wired remote controller connector.

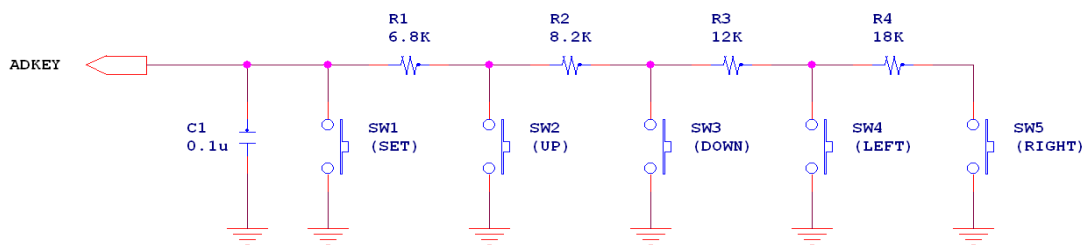

**3. MD (J101-12)**

Port giving signal output of Motion Detection Alarm

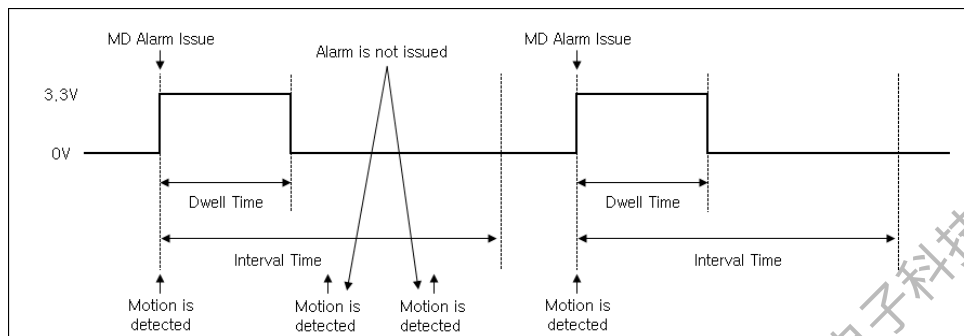

深圳市凯莱锐电子科技有限公司

Block Diagram

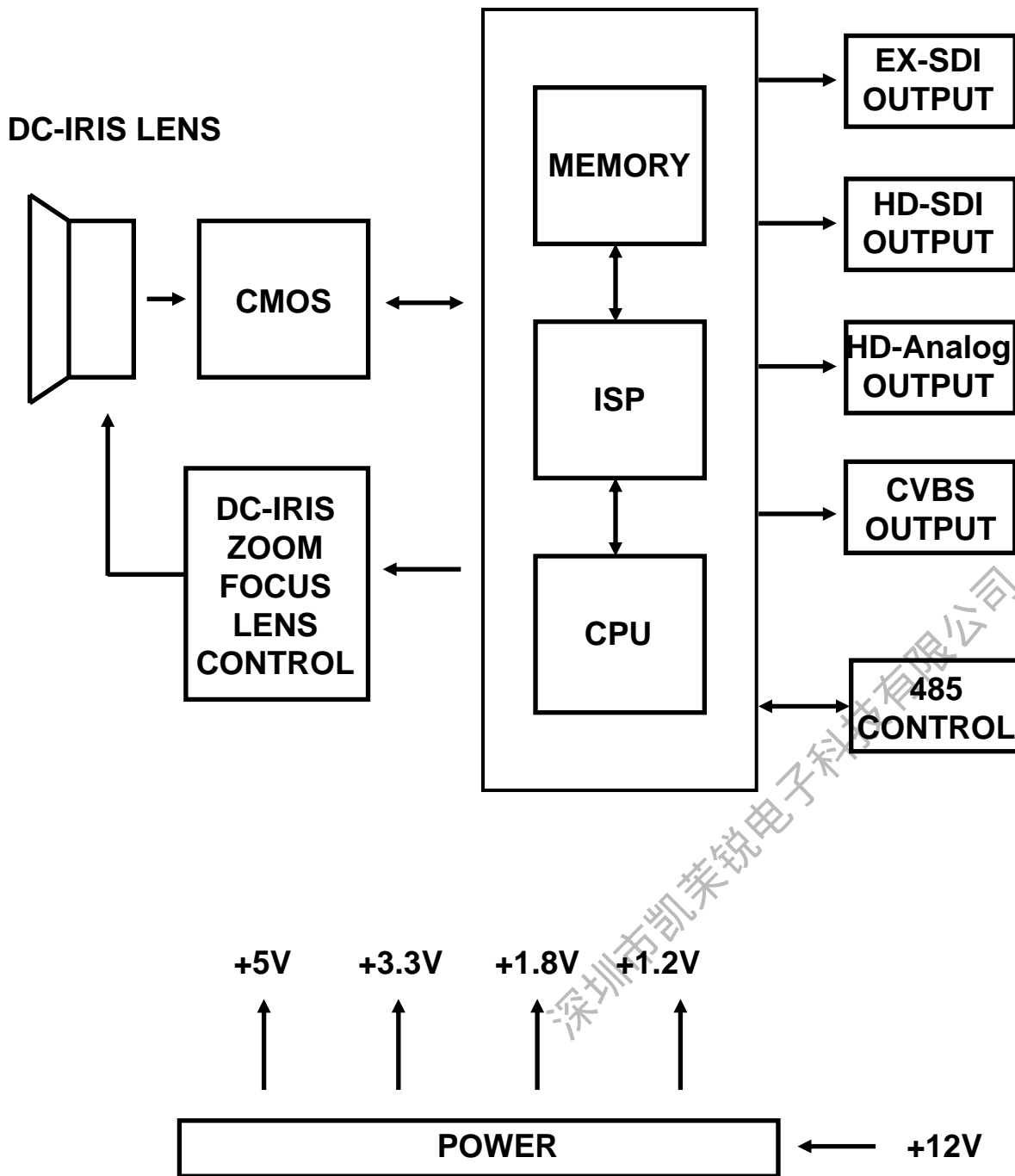



## Protocol

### 1. Timing

As Command processing can only be carried out one time in a Vertical cycle, it takes the maximum 1V cycle time for an ACK/Completion to be returned. If the Command ACK/Completion communication time can be cut shorter than the 1V cycle time, then every 1V cycle can receive a Command.

#### ※ 1V cycle

- 30fps mode : 33.3ms
- 60fps mode : 16.7ms
- 25fps mode : 40.0ms
- 50fps mode : 20.0ms

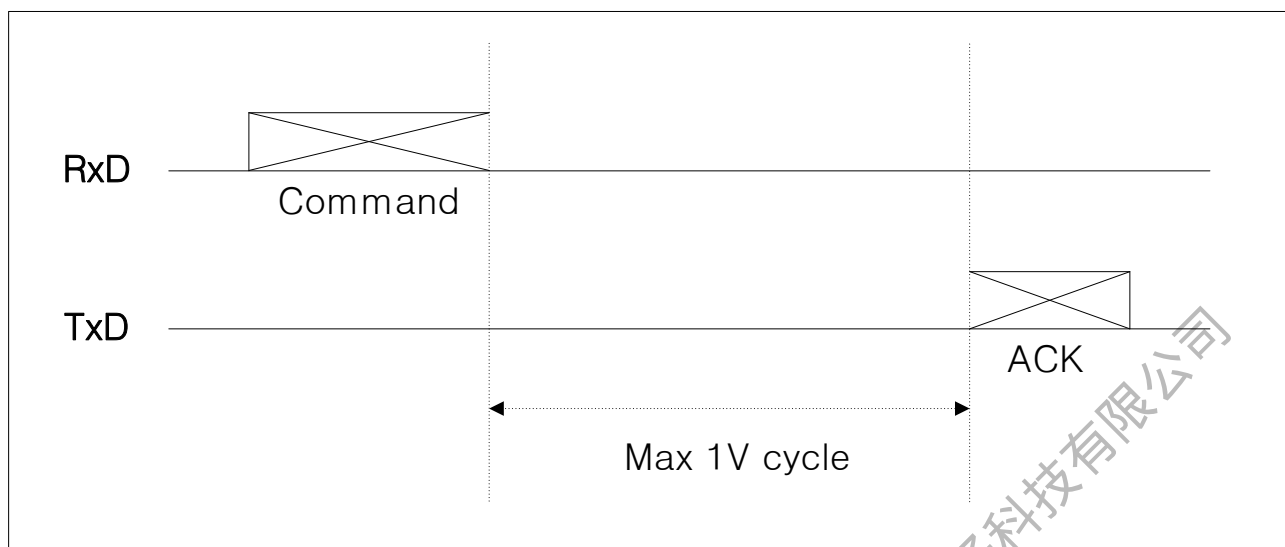

### 2. Communication parameter

- Protocol : VISCA, Pelco-D, Pelco-P, UPDATE
- ID : 1~7 (VISCA), 1~255(Pelco-D, Pelco-P)
- Baud rate : 2400, 4800, 9600, 19200, 38400, 57600, 115200 bps
- Data bit : 8
- Start bit : 1
- Stop bit : 1
- Non parity bit

**Protocol**

## 3. Pelco-D Protocol Command List

Function	Message format (Hex)						
	Byte1	Byte2	Byte3	Byte4	Byte5	Byte6	Byte7
Zoom Tele	FF	ID	00	20	00	00	CS
Zoom Wide	FF	ID	00	40	00	00	CS
Stop	FF	ID	00	00	Don't care		CS
Menu (Set)	FF	ID	00	03 or 07	00	5F	CS
Esc	FF	ID	00	03 or 07	00	60	CS
Up	FF	ID	00	08	00	XX	CS
Down	FF	ID	00	10	00	XX	CS
Left	FF	ID	00	04	XX	00	CS
Right	FF	ID	00	02	XX	00	CS

- ID : Camera ID (1 ~ 255)
- XX : Speed (10h < XX ≤ 40h)
- CS(Check Sum) : An 8bit sum of byte 2 ~ 6 in the message.

## 4. Pelco-P Protocol Command List

Function	Message format (Hex)							
	Byte1	Byte2	Byte3	Byte4	Byte5	Byte6	Byte7	Byte8
Zoom Tele	A0	ID	00	20	00	00	AF	CS
Zoom Wide	A0	ID	00	40	00	00	AF	CS
Stop	A0	ID	00	00	Don't care		AF	CS
Menu (Set)	A0	ID	00	03 or 07	00	5F	AF	CS
Esc	A0	ID	00	03 or 07	00	60	AF	CS
Up	A0	ID	00	08	00	XX	AF	CS
Down	A0	ID	00	10	00	XX	AF	CS
Left	A0	ID	00	04	XX	00	AF	CS
Right	A0	ID	00	02	XX	00	AF	CS

- ID : Camera ID (1 ~ 255)
- XX : Speed (10h < XX ≤ 40h)
- CS(Check Sum) : An XOR sum of byte 1 ~ 7 in the message.

**Protocol**

5. Visca Protocol

● Command packet (Variable packet length)

Byte 0	Byte 1	Byte 2	...	Byte n-2	Byte n-1
Header	Message				Terminator
8Xh	QQ	...			FFh

Bit7	Bit6	Bit5	Bit4	Bit3	Bit2	Bit1	Bit0
1	0	0	0	0	x	x	x
Sender's address				Receiver's address			

- X : 1 ~ 7 (Camera address)
- QQ : 01 (Command), 09 (Inquiry)

● Ack message packet (Variable packet length)

Byte 0	Byte 1	Byte 2	...	Byte n-2	Byte n-1
Header	Message				Terminator
Y0h	QR	...			FFh

Bit7	Bit6	Bit5	Bit4	Bit3	Bit2	Bit1	Bit0
1	y	y	y	0	0	0	0
Sender's address				Receiver's address			

- Y : 9 ~ F (Camera address + 8)
- Q : 4 (Receive Ack), 5 (Completion message), 6 (Error message)
- R : Socket Number (1 ~ 3)

※ When command messages are sent to the camera, it is normal to send the next command message after waiting for the completion message or error message to return. However to deal with advanced uses, the camera has three buffers (memories) for commands, so that up to three commands including the commands currently being executed can be received. When the camera receives commands, it notifies the sender which command buffer was used using the socket number of the ACK

Ack type	Reply packet
Recevie Ack	Y0 4R FF
Compeletion (Commands)	Y0 5R FF
Compeletion (Inquiries)	Y0 50 ... FF
Error	Y0 6R SS FF

SS	Description
01	Message length error
02	Syntax error
03	Command buffer full
04	Command cancelled
05	No socket (to be cancelled)
41	Command not executable

**Protocol**

● Example of communication

- Camera ID : 1
- Socket number : 1

※ Command

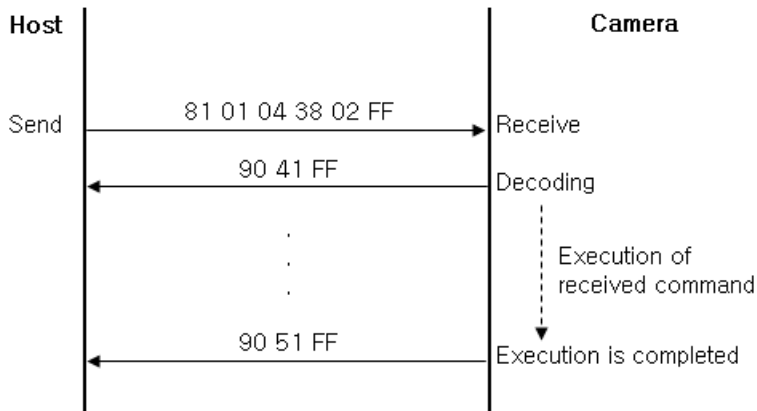

※ Inquiry command

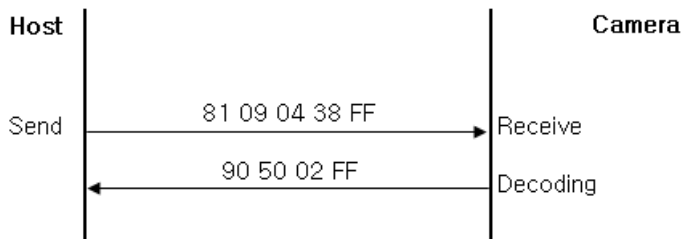

● Network change message

- Sent from the peripheral device to the controller when a device is removed from or added to the network. The address must be re-set when this message is received.

Y0 38 FF

- Y : 9 ~ F (Camera address + 8)

深圳市凯莱锐电子科技有限公司



**Command List**

## &lt; Command &gt;

Command Set	Command	Command Packet	Comments
AddressSet	Broadcast	88 30 01 FF	Address setting
IF_Clear	Broadcast	88 01 00 01 FF	I/F Clear
		8x 01 00 01 FF	
CommandCancel		8x 2p FF	p : Socket No.(1 ~ 3)
CAM_Power	Power Reset	8x 01 04 00 03 FF	Camera Rebooting
CAM_Dzoom	On	8x 01 04 06 02 FF	Digital Zoom ON/OFF
	Off	8x 01 04 06 03 FF	
	Stop	8x 01 04 06 00 FF	
	Tele (Variable)	8x 01 04 06 2p FF	p : 0(Slow) ~ 7(Fast)
	Wide (Variable)	8x 01 04 06 3p FF	
	x1/Max	8x 01 04 06 10 FF	x1/Max Magnification switchover
Direct		8x 01 04 46 00 00 0p 0q FF	pq : D-Zoom Position
CAM_Initialize	Comp Scan	8x 01 04 19 02 FF	Execute White spot compensation
	Comp Scan Thrs	8x 01 04 19 03 00 0p 0q FF	pq : Threshold of White spot compensation
CAM_WB	Auto	8x 01 04 35 00 FF	Normal Auto
	Indoor	8x 01 04 35 01 FF	Indoor Mode
	Outdoor	8x 01 04 35 02 FF	Outdoor Mode
	One Push AWB	8x 01 04 35 03 FF	One Push AWB Mode
	Manual	8x 01 04 35 05 FF	Manual Control Mode
	Auto-Ext	8x 01 04 35 07 FF	Auto Extended Mode
	One Push Trigger	8x 01 04 10 05 FF	One Push AWB trigger
CAM_Rgain	Reset	8x 01 04 03 00 FF	R Gain Manual setting
	Up	8x 01 04 03 02 FF	
	Down	8x 01 04 03 03 FF	
	Direct		8x 01 04 43 00 00 0p 0q FF
CAM_Bgain	Reset	8x 01 04 04 00 FF	B Gain Manual setting
	Up	8x 01 04 04 02 FF	
	Down	8x 01 04 04 03 FF	
	Direct		8x 01 04 44 00 00 0p 0q FF
CAM_Chroma	Direct	8x 01 04 13 00 00 0p 0q FF	pq : Chroma level (0~14h)
CAM_LENS	Mode	8x 01 04 49 01 00 0q FF	q : Lens Mode (0:Indoor, 1:Outdoor, 2:Deblur)
CAM_ShutterMode	Auto	8x 01 04 39 00 FF	Auto exposure mode
	Manual	8x 01 04 39 03 FF	Manual control mode
CAM_Shutter	Reset	8x 01 04 0A 00 FF	Shutter setting
	Up	8x 01 04 0A 02 FF	
	Down	8x 01 04 0A 03 FF	
	Direct		8x 01 04 4A 00 00 0p 0q FF

**Command List**

## &lt; Command &gt;

Command Set	Command	Command Packet	Comments
CAM_Gain	Gain Limit	8x 01 04 2C 0p FF	AGC Limit (0~10)
CAM_SlowShutter	Auto (On)	8x 01 04 5A 02 FF	Auto Slow Shutter ON/OFF
	Manual (Off)	8x 01 04 5A 03 FF	
CAM_MaxDSSLev	Direct	8x 01 04 5A 1p FF	p :Max Slow shutter level (0:x2, 1:x4, 2:x8, 3:x16, 4:x32, 5:x64) ※ You can't select "x64" in 30 or 25 fps mode
CAM_ExpComp	On	8x 01 04 3E 02 FF	Exposure Compensation ON/OFF
	Off	8x 01 04 3E 03 FF	
	Reset	8x 01 04 0E 00 FF	Exposure Compensation amount setting
	Up	8x 01 04 0E 02 FF	
	Down	8x 01 04 0E 03 FF	
	Direct	8x 01 04 4E 00 00 0p 0q FF	
CAM_Flickerless	On	8x 01 04 7A 02 FF	Flickerless ON/OFF
	Off	8x 01 04 7A 03 FF	
CAM_BLC	On	8x 01 04 33 02 FF	Back Light Compensation
	Off	8x 01 04 33 03 FF	
CAM_BLCFunc	Area OSD Display	8x 01 04 3C 0p FF	p : 0(Area OSD Off), 1(Area OSD On)
	Area Start X	8x 01 04 3C 10 00 0p 0q FF	pq : Start Horizontal Position (0 ~ 34h)
	Area Start Y	8x 01 04 3C 20 00 0p 0q FF	pq : Start Vertical Position (0 ~ 36h)
	Area End X	8x 01 04 3C 30 00 0p 0q FF	pq : End Horizontal Position (6 ~ 3Ah)
	Area End Y	8x 01 04 3C 40 00 0p 0q FF	pq : End Vertical Position (Ah ~ 40h)
CAM_HLC	Mode	8x 01 04 32 0p FF	p : HLC Mode - 0(Off), 1(On), 2(Night Only)
	Level	8x 01 04 32 10 00 0p 0q FF	pq : HLC Level (0 ~ 14h)
	Clip Color	8x 01 04 32 3p FF	p : HLC Color (0:BLK, 1~6:Gray1~6, 7:WHT, 8:RED, 9:GRN, Ah:BLU, Bh:CYN, Ch:YEL, Dh:MAG)
CAM_WD	On	8x 01 04 3D 02 FF	Wide-D ON/OFF
	Off	8x 01 04 3D 03 FF	
CAM_WD_Mode	Frame mode	8x 01 04 6D 00 FF	Frame WDR mode
	Line mode	8x 01 04 6D 01 FF	Line WDR mode
CAM_WD_Level	Direct	8x 01 04 7D 0p FF	p : WDR Level (0 ~ 4)
CAM_ACE	On	8x 01 04 1A 02 FF	ACE ON/OFF
	Off	8x 01 04 1A 03 FF	
CAM_ACELevel	Direct	8x 01 04 1A 10 0p FF	p : ACE Level (0 ~ 2)
CAM_Defog	On	8x 01 04 65 02 FF	Defog ON/OFF
	Off	8x 01 04 65 03 FF	
	Level	8x 01 04 65 10 0p FF	p : Defog Level(0 ~ 2)
	Mode	8x 01 04 65 20 0p FF	p : 0(Manual), 1(Auto)
CAM_DNR	Mode	8x 01 04 53 0p FF	p : 0 (Off), 1 ~ 3 (Manual Level), 4 ( Auto)
CAM_GAMMA	Direct	8x 01 04 5B 0p FF	p: Gamma setting (0:0.45, 1:0.55, 2:0.65, 3:0.75)

**Command List**

## &lt; Command &gt;

Command Set	Command	Command Packet	Comments
CAM_Aperture	Reset	8x 01 04 02 00 FF	Aperture Control
	Up	8x 01 04 02 02 FF	
	Down	8x 01 04 02 03 FF	
	Direct	8x 01 04 42 00 00 0p 0q FF	pq : Aperture Gain (0~14h)
CAM_LR_Reverse	On	8x 01 04 61 02 FF	Mirror Image ON/OFF
	Off	8x 01 04 61 03 FF	
CAM_Freeze	On	8x 01 04 62 02 FF	Freeze Picture ON/OFF
	Off	8x 01 04 62 03 FF	
CAM_PictureFlip	On	8x 01 04 66 02 FF	Picture Reverse On/Off (Rotate 180°)
	Off	8x 01 04 66 03 FF	
CAM_ICR	Night	8x 01 04 01 02 FF	ICR Mode ON/OFF
	Day	8x 01 04 01 03 FF	
	Auto	8x 01 04 51 02 FF	ICR is changed automatically by AGC Gain
	Ext-In	8x 01 04 51 05 FF	ICR is changed by external input
	Threshold	8x 01 04 21 00 00 0p 0q FF	pq : Threshold level of Auto mode (0 ~ 1Ch)
	Gap	8x 01 04 21 10 00 0p 0q FF	pq : On/Off Threshold Gap of Auto mode (0 ~ 4)
	Auto ICR Delay	8x 01 04 41 00 00 0p 0q FF	pq : Auto mode delay - 0(0sec) ~ FFh(255sec)
	Ext-In Delay	8x 01 04 71 00 00 0p 0q FF	pq : Ext-In mode delay - 0(0sec) ~ FFh(255sec)
	Burst On	8x 01 04 72 02 FF	Burst On/Off
	Burst Off	8x 01 04 72 03 FF	
	IR Detection On	8x 01 04 6E 02 FF	IR Detection On/Off
	IR Detection Off	8x 01 04 6E 03 FF	
	IR Detection Level	8x 01 04 6E 10 0p FF	p : IR Detection Threshold Level (0 ~ 4)
CAM_MEMORY	Reset	8x 01 04 3F 00 0p FF	p : Memory number (0 ~ Ah)
	Set	8x 01 04 3F 01 0p FF	
	Recall	8x 01 04 3F 02 0p FF	
CAM_CUSTOM	Reset	8x 01 04 3F 00 7F FF	Starts in this mode at Power On
	Set	8x 01 04 3F 01 7F FF	
	Recall	8x 01 04 3F 02 7F FF	
CAM_MemSave	Write	8x 01 04 23 0t 0p 0q 0r 0s FF	t : 00 ~ 07 (Address) Total 16Byte pqrs : 0000 ~ FFFFh (Data)
CAM_Display	On	8x 01 04 15 02 FF	Display ON/OFF
	Off	8x 01 04 15 03 FF	
	On/Off	8x 01 04 15 10 FF	
CAM_DispSel		8x 01 04 14 00 0p FF	Display Item : On(1)/Off(0) p : bit[0] - ID, bit[1] - Title, bit[2] - Zoom Position bit[3] - System Message (MD, Zoom Preset)

**Command List**

## &lt; Command &gt;

Command Set	Command	Command Packet	Comments
CAM_MultiLineTitle	Title Set1	8x 01 04 73 1L 00 nn 00 00 00 00 00 00 00 00 FF	L : Line Number (0 ~ Eh) nn : H-Position (0 ~ 27h)
	Title Set2	8x 01 04 73 2L mm nn pp qq rr ss tt uu vv ww FF	L : Line Number (0 ~ Eh) mnpqrstuvw : Set of characters (1 ~ 10)
	Title Set3	8x 01 04 73 3L mm nn pp qq rr ss tt uu vv ww FF	L : Line Number (0 ~ Eh) mnpqrstuvw : Set of characters (11~ 20)
	Title Clear	8x 01 04 74 1p FF	Title Set clear (p: 0 ~ Eh, Fh= all line)
	On	8x 01 04 74 2p FF	Title display On/Off (0 ~ Eh, Fh= all line)
	Off	8x 01 04 74 3p FF	
CAM_MENUKey	Up	8x 01 04 16 01 FF	
	Down	8x 01 04 16 02 FF	
	Left	8x 01 04 16 04 FF	
	Right	8x 01 04 16 08 FF	
	Menu	8x 01 04 16 10 FF	
	ESC	8x 01 04 16 20 FF	
CAM_Use OSD	Display String	8x 01 05 10 xx yy cc ss "nnnnnnnnnnnn" FF	xx : X position (0 ~ 27h ) yy : Y Position (0 ~ Eh ) cc : Color (Fixed, 07 : White) ss : NORMAL = 00 INVERSE = 01 BLINK = 02 "nnnnn...." : Display String (Max 26 char)
	Blue Screen	8x 01 05 20 pq FF	p : Transparency (0:0%, 1:25%, 2:50%, 3:75%) q : Blue Screen Display - 0(Off), 1(On)
	Screen Clear	8x 01 05 30 01 FF	Screen All clear
CAM_Mute	On	8x 01 04 75 02 FF	Mute On/Off
	Off	8x 01 04 75 03 FF	
	On/Off	8x 01 04 75 10 FF	
CAM_PrivacyZone	Display	8x 01 04 77 pp pp pp pp FF	Mask Display On/Off pppppppp : Mask Settings (0: OFF, 1: ON)
	SetMaskColor	8x 01 04 78 pp pp pp pp qq rr FF	pppppppp : Mask Color Settings qq : Color Setting when 0 is selected rr : Color Setting when 1 is selected
	Non_InterlockMask	8x 01 04 6F mm 0p 0p 0q 0q 0r 0r 0s 0s FF	mm : Non-Interlock Mask Number pp : X, qq : Y, rr : W, ss : H
CAM_KeyLock	Off	8x 01 04 17 02 FF	Key Lock On/Off
	On	8x 01 04 17 03 FF	
CAM_IDWrite		8x 01 04 22 0p 0q 0r 0s FF	pqrs : Camera ID (0000 ~ FFFFh)

**Command List**

## &lt; Command &gt;

Command Set	Command	Command Packet	Comments
CAM_MD	On	8x 01 04 1B 02 FF	Motion Detection On/Off
	Off	8x 01 04 1B 03 FF	
	Function Set	8x 01 04 1C 0m 0n 0p 0q 0r 0s FF	m : Display mode n : Detection Frame Set (bit[0]:1, bit[1]:2, bit[3]:3) pq : Threshold Level (00 ~ 14h) rs : Interval Time set (00 ~ FFh)
	Window Set	8x 01 04 1D 0m 0p 0q 0r 0s FF	m : Select Detection Frame Number (0, 1, 2) p : Start Horizontal Position (0 ~ Dh) q : Start Vertical Position (0 ~ 7) r : End Horizontal Position (1 ~ Eh) s : End Vertical Position (1 ~ 8)
	Alarm(Reply)	y0 07 04 1B 0p FF	p : Detection Frame Number
CAM_RegisterValue		8x 01 04 24 mm 0p 0q FF	mm : Register No. (00, 52h, 60h, 72h, 73h, 90h, 91h, 9Ah) pq : Register Value
CAM_ColorHue	Direct	8x 01 04 4F 00 00 00 0p FF	p:Color Hue setting (0 : -14° ~ Eh : +14°)
CAM_UTC	On	8x 01 05 1C 02 FF	UTC On/Off
	Off	8x 01 05 1C 03 FF	
CAM_UTCForward	On	8x 01 05 0C 02 FF	UTC to UART forwarding On/Off
	Off	8x 01 05 0C 03 FF	
	(Reply) ※ HD-T	y0 07 05 0C 0p 0p 0q 0q 0r 0r 0s 0s 0t 0t 0u 0u 0v 0v 0w 0w FF	pp : Byte 1 qq : Byte 2 rr : Byte 3 ss : Byte 4 tt : Byte 5 uu : Byte 6 vv : Byte 7 ww : Byte 8

**Command List**
**< Inquiry Command >**

Inquiry Command	Command Packet	Inquiry Packet	Comments
CAM_DZoomModelnq	8x 09 04 06 FF	y0 50 02 FF	D-Zoom On
		y0 50 03 FF	D-Zoom Off
CAM_DZoomPosnq	8x 09 04 46 FF	y0 50 00 00 0p 0q FF	pq : D-Zoom Position
CAM_CompScanThrsnq	8x 01 04 19 03 FF	y0 50 00 00 0p 0q FF	pq : White spot compensation Threshold (0~FFh)
CAM_WBModelnq	8x 09 04 35 FF	y0 50 00 FF	Auto
		y0 50 01 FF	Indoor
		y0 50 02 FF	Outdoor
		y0 50 03 FF	One Push AWB
		y0 50 05 FF	Manual
		y0 50 07 FF	Auto-Ext
CAM_RGainnq	8x 09 04 43 FF	y0 50 00 00 0p 0q FF	pq : R Gain (0~14h)
CAM_BGainnq	8x 09 04 44 FF	y0 50 00 00 0p 0q FF	pq : B Gain (0~14h)
CAM_Chromanq	8x 09 04 13 FF	y0 50 00 00 0p 0q FF	pq : Chroma level (0~14h)
CAM_LensModelnq	8x 09 04 49 01 FF	y0 50 00 00 00 0q FF	q : Lens Mode (0 : Indoor, 1 : Outdoor, 2 : Deblur)
CAM_ShutterModelnq	8x 09 04 39 FF	y0 50 00 FF	Auto
		y0 50 03 FF	Manual
CAM_ShutterPosnq	8x 09 04 4A FF	y0 50 00 00 0p 0q FF	pq : Shutter Position
CAM_SlowShutterModelnq	8x 09 04 5A FF	y0 50 02 FF	Auto
		y0 50 03 FF	Off
CAM_MaxDSSLevnq	8x 09 04 5A 10 FF	y0 50 0p FF	p :Max Slow shutter level (0:x2, 1:x4, 2:x8, 3:x16, 4:x32, 5:x64) ※ You can't select "x64" in 30 or 25 fps mode
CAM_GainLimitnq	8x 09 04 2C FF	y0 50 0p FF	p : Auto gain limit (0 ~ 10)
CAM_ExpCompModelnq	8x 09 04 3E FF	y0 50 02 FF	On
		y0 50 03 FF	Off
CAM_ExpCompPosnq	8x 09 04 4E FF	y0 50 00 00 0p 0q FF	pq : ExpComp Position
CAM_Flickerlessnq	8x 09 04 7A FF	y0 50 02 FF	On
		y0 50 03 FF	Off
CAM_BLCModelnq	8x 09 04 33 FF	y0 50 02 FF	On
		y0 50 03 FF	Off
CAM_BLCAreanq	8x 09 04 3C 00 FF	y0 50 0p FF	p : BLC Mode - 0(AREA OSD Off), 1(AREA OSD On)
CAM_BLC_StartXInq	8x 09 04 3C 10 FF	y0 50 00 00 0p 0q FF	pq : Start Horizontal Position (0 ~ 34h)
CAM_BLC_StartYInq	8x 09 04 3C 20 FF	y0 50 00 00 0p 0q FF	pq : Start Vertical Position (0 ~ 36h)
CAM_BLC_EndXInq	8x 09 04 3C 30 FF	y0 50 00 00 0p 0q FF	pq : End Horizontal Position (6 ~ 3Ah)
CAM_BLC_EndYInq	8x 09 04 3C 40 FF	y0 50 00 00 0p 0q FF	pq : End Vertical Position (Ah ~ 40h)
CAM_HLCModelnq	8x 09 04 32 00 FF	y0 50 0p FF	p : HLC Mode - 0(Off), 1(On), 2(Night)
CAM_HLCLevellnq	8x 09 04 32 10 FF	y0 50 00 00 0p 0q FF	pq : HLC Level (0 ~ 14h)
CAM_HLCColorInq	8x 09 04 32 30 FF	y0 50 0p FF	p : HLC Color (0:BLK, 1~6:Gray1~6, 7:WHT, 8:RED, 9:GRN, Ah:BLU, Bh:CYN, Ch:YEL, Dh:MAG)

**Command List**
**< Inquiry Command >**

Inquiry Command	Command Packet	Inquiry Packet	Comments
CAM_WDRInq	8x 09 04 3D FF	y0 50 02 FF	On
		y0 50 03 FF	Off
CAM_WDModelnq	8x 09 04 6D FF	y0 50 00 FF	Frame WDR mode
		y0 50 01 FF	Line WDR mode
CAM_WDLevelInq	8x 09 04 7D FF	y0 50 0p FF	p : WDR Level (0 ~ 4)
CAM_ACEInq	8x 01 04 1A FF	y0 50 02 FF	On
		y0 50 03 FF	Off
CAM_ACELevelInq	8x 09 04 1A 10 FF	y0 50 0p FF	p : ACE Level (0 ~ 2)
CAM_DefogInq	8x 09 04 65 FF	y0 50 02 FF	On
		y0 50 03 FF	Off
CAM_DefogLevelInq	8x 09 04 65 10 FF	y0 50 0p FF	p : Defog Level (0 ~ 2)
CAM_DefogModelnq	8x 09 04 65 20 FF	y0 50 0p FF	p : Defog Mode - 0(Manual), 1(Auto)
CAM_DNRModelnq	8x 09 04 53 FF	y0 50 0p FF	p : 0 (Off), 1 ~ 3 (Manual Level), 4 (Auto)
CAM_GammaInq	8x 09 04 5B FF	y0 50 0p FF	p: Gamma setting (0:0.45, 1:0.55, 2:0.65, 3:0.75)
CAM_ApertureInq	8x 09 04 42 FF	y0 50 00 00 0p 0q FF	pq: Aperture Gain (0 ~ 14h)
CAM_LR_ReverseModelnq	8x 09 04 61 FF	y0 50 02 FF	On
		y0 50 03 FF	Off
CAM_FreezeModelnq	8x 09 04 62 FF	y0 50 02 FF	On
		y0 50 03 FF	Off
CAM_PictureFlipModelnq	8x 09 04 66 FF	y0 50 02 FF	On
		y0 50 03 FF	Off
CAM_ICRStateInq	8x 09 04 01 FF	y0 50 02 FF	Night
		y0 50 03 FF	Day
CAM_ICRModelnq	8x 09 04 51 FF	y0 50 02 FF	Night
		y0 50 03 FF	Day
		y0 50 04 FF	ICR is changed automatically by AGC Gain
		y0 50 06 FF	ICR is changed by external input
CAM_ICRThresholdInq	8x 09 04 21 FF	y0 50 00 00 0p 0q FF	pq : Threshold level of Auto Mode (0 ~ 1Ch)
CAM_ICRGapInq	8x 09 04 21 10 FF	y0 50 00 00 0p 0q FF	p : On/Off Threshold Gap of Auto mode(0 ~ 4)
CAM_AutoICRDelayInq	8x 09 04 41 FF	y0 50 00 00 0p 0q FF	pq : Auto mode delay - 0(0sec)~FFh(255sec)
CAM_Ext-InICRDelayInq	8x 09 04 71 FF	y0 50 00 00 0p 0q FF	pq : Ext-In mode delay - 0(0sec)~FFh(255sec)
CAM_BurstInq	8x 09 04 72 FF	y0 50 02 FF	On
		y0 50 03 FF	Off
CAM_IRDetectionInq	8x 09 04 6E FF	y0 50 02 FF	On
		y0 50 03 FF	Off
CAM_IRDetectionLevelInq	8x 09 04 6E 10 FF	y0 50 0p FF	p : IR Detection Threshold Level (0 ~ 4)
CAM_MemoryInq	8x 09 04 3F FF	y0 50 0p FF	p: Last Recall Memory No.
CAM_MemSaveInq	8x 09 04 23 0t FF	y0 50 0p 0q 0r 0s FF	t : 0 ~ 7 (Address) pqrs : 0000 ~ FFFFh (Data)
CAM_DisplayInq	8x 09 04 15 FF	y0 50 02 FF	On
		y0 50 03 FF	Off

## Command List

## &lt; Inquiry Command &gt;

Inquiry Command	Command Packet	Inquiry Packet	Comments
CAM_DispSellInq	8x 09 04 14 00 FF	y0 50 0p FF	Display Item On(1)/Off(0) p : bit[0] - ID, bit[1] - Title, bit[2] - Zoom Position, bit[3] - System Message
CAM_TitleDisplayModelInq	8x 09 04 74 FF	y0 50 02 FF	On
		y0 50 03 FF	Off
CAM_MenuModelInq	8x 09 04 16 FF	y0 50 02 FF	OSD menu On
		y0 50 03 FF	OSD menu Off
CAM_BlueScreenModelInq	8x 09 05 20 FF	y0 50 pq FF	p : Transparency (0:0%, 1:25%, 2:50%, 3:75%) q : Blue Screen Display - 0(Off), 1(On)
CAM_MuteModelInq	8x 09 04 75 FF	y0 50 02 FF	On
		y0 50 03 FF	Off
CAM_PrivacyPosInq	8x 09 04 76 mm FF	y0 50 0n 0p 0p 0r 0r 0s 0s FF	mm : Mask Number n : 0(Non-interlock Mode), 1(Interlock Mode) pp : X, qq : Y, rr : W, ss : H
CAM_PrivacyDisplayInq	8x 09 04 77 FF	y0 50 pp pp pp pp FF	pppppppp : Mask Display (0: OFF, 1: ON)
CAM_PrivacyColorInq	8x 09 04 78 FF	y0 50 pp pp pp pp qq rr FF	pppppppp : Mask Color Setting qq : Color Setting when 0 is selected Rr : Color Setting when 1 is selected
CAM_PrivacyMonitorInq	8x 09 04 6F FF	y0 50 pp pp pp pp FF	pppppppp : Mask is displayed now
CAM_KeyLockInq	8x 09 04 17 FF	y0 50 02 FF	On
		y0 50 00 FF	Off
CAM_IDInq	8x 09 04 22 FF	y0 50 0p 0q 0r 0s FF	pqrs: Camera ID
CAM_VersionInq	8x 09 00 02 FF	y0 50 00 20 mn pq rs tu vw FF	mnpq : Model Code (0466h) rstu : ROM version (0100h) vw : Socket Number (3)
CAM_ModelInq	8x 09 00 37 FF	y0 50 pp pp pp qq qq FF	pppppp : Model Code – YY0438h (YY : Custom. Code, standard model = 00) qqqq : Version
CAM_MDModelInq	8x 09 04 1B FF	y0 50 02 FF	On
		y0 50 03 FF	Off
CAM_MDFunctionInq	8x 09 04 1C FF	y0 50 0m 0n 0p 0q 0r 0s FF	m : Display mode n : Detection Frame Set (bit[0]:1, bit[1]:2, bit[3]:3) pq : Threshold Level (00 ~ 14h) rs : Interval Time set (00 ~ FFh)
CAM_MDWindowInq	8x 09 04 1D 0m FF	y0 50 0p 0q 0r 0s FF	m : Select Detection Frame Number (0, 1, 2) p : Start Horizontal Position (0 ~ Dh) q : Start Vertical Position (0 ~ 7) r : End Horizontal Position (1 ~ Eh) s : End Vertical Position (1 ~ 8)



**Command List**

## &lt; Inquiry Command &gt;

Inquiry Command	Command Packet	Inquiry Packet	Comments
CAM_RegisterValueInq	8x 09 04 24 mm FF	y0 50 0p 0p FF	mm : Register No. (00, 52h, 60h, 72h, 73h, 90h, 91h, 9Ah) pp : Register Value
CAM_ColorHueInq	8x 09 04 4F FF	y0 50 00 00 00 0p FF	p:Color Hue setting (0 : -14° ~ Eh : +14°)
CAM_UTCInq	8x 09 05 1C FF	y0 50 02 FF	On
		y0 50 03 FF	Off
CAM_UTCForwardInq	8x 09 05 0C FF	y0 50 02 FF	OSD menu On
		y0 50 03 FF	OSD menu Off

深圳市凯莱锐电子科技有限公司

**Command List**

## &lt; Exposure control values &gt;

**Shutter Speed (Hex)**

Step (Hex)	NTSC	PAL
13	1/60000	1/60000
12	1/30000	1/30000
11	1/20000	1/20000
10	1/10000	1/10000
0F	1/6000	1/6000
0E	1/3000	1/3000
0D	1/2000	1/2000
0C	1/1000	1/1000
0B	1/700	1/700
0A	1/500	1/500
9	1/250	1/250
8	1/120	1/120
7	1/100	1/100
6	1/60	1/50
5	1/30	1/25

**Gain (Hex)**

Step (Hex)	GAIN
0A	77.7dB
09	70.5dB
08	63.3dB
07	56.1dB
06	48.9dB
05	41.7dB
04	34.5dB
03	27.3dB
02	20.1dB
01	12.9dB
00	0dB

## &lt; D-Zoom control values &gt;

**D-Zoom : Separate Mode**

Magnification	Zoom Position
x1	00
x2	80
x3	AA
x4	C0
x5	CC
x6	D5
x7	DB
x8	E0
x9	E3
x10	E6
x11	E8
x12	EB
x13	ED
x14	EE
x15	EF
x16	F0
x17	F1
x18	F2
x19	F3
x21	F4
x23	F5
x25	F6
x28	F7
x32	F8

**Command List**

**< OSD character values >**

V position	00 ~ 0Eh	15 Rows
H position	00 ~ 27h	40 Columns

**Character code**

Code	Character	Code	Character	Code	Character	Code	Character
00	Space	21	A	42	b	63	Ç
01	!	22	B	43	c	64	È
02	"	23	C	44	d	65	É
03	#	24	D	45	e	66	Ê
04	\$	25	E	46	f	67	Ë
05	%	26	F	47	g	68	Ë
06	&	27	G	48	h	69	Ï
07		28	H	49	i	6A	Ñ
08	(	29	I	4A	j	6B	Ô
09	)	2A	J	4B	k	6C	Ö
0A	*	2B	K	4C	l	6D	Ù
0B	+	2C	L	4D	m	6E	Û
0C	,	2D	M	4E	n	6F	Ü
0D	-	2E	N	4F	o	70	ß
0E	.	2F	O	50	p	71	à
0F	/	30	P	51	q	72	á
10	0	31	Q	52	r	73	ä
11	1	32	R	53	s	74	ç
12	2	33	S	54	t	75	è
13	3	34	T	55	u	76	é
14	4	35	U	56	v	77	ê
15	5	36	V	57	w	78	ë
16	6	37	W	58	x	79	Ë
17	7	38	X	59	y	7A	Ï
18	8	39	Y	5A	z	7B	ñ
19	9	3A	Z	5B	{	7C	ô
1A	:	3B	[	5C		7D	ö
1B	;	3C	\	5D	}	7E	ù
1C	<	3D	]	5E	~	7F	û
1D	=	3E	^	5F		80	ü
1E	>	3F	_	60	À	81	œ
1F	?	40	`	61	Á	82	œ
20	@	41	a	62	Ä		

**Command List**

## &lt; Register Setting &gt;

Function	Register No.	Value	
BaudRate	00	10	2400 bps
		11	4800 bps
		00	9600 bps
		01	19200 bps
		02	38400 bps
		03	57600 bps
		04	115200 bps
E.ZOOM Max	52	00 ~ F8	Max. DZoom Ratio = 256 / (256 - Value)
Language	60	00	English
		01	Japanese
		03	Simplified Chinese
		05	Traditional Chinese
Monitoring Mode	72	01	1080i/60fps
		04	1080i/50fps
		06	1080p/30fps
		08	1080p/25fps
		09	720p/60fps
		0C	720p/50fps
		0E	720p/30fps
		11	720p/25fps
		13	1080p/60fps
		14	1080p/50fps
Output Enabling	73	0	Analog Output disabled
		1	CVBS
		2	HD-T
Image range mode	90	0	Full mode
		1	Comp mode
		2	User mode
Image range custom level	91	0 ~ 20	
SDI mode	9A	0	Off
		1	HD-SDI
		2	EX-SDI 135M (v2.0)
		3	EX-SDI 135M+ (v2.1)
		4	EX-SDI 270M (v1.0)

**Command List****< Other control values >**

R Gain	00	~	14h
B Gain	00	~	14h
Aperture Level	00	~	0Ah
Threshold Level of ICR	00	~	1Ch
Gap Level of ICR	00	~	04h

深圳市凯莱锐电子科技有限公司

 OSD Menu

## III. OSD

## ◆ Main Menu

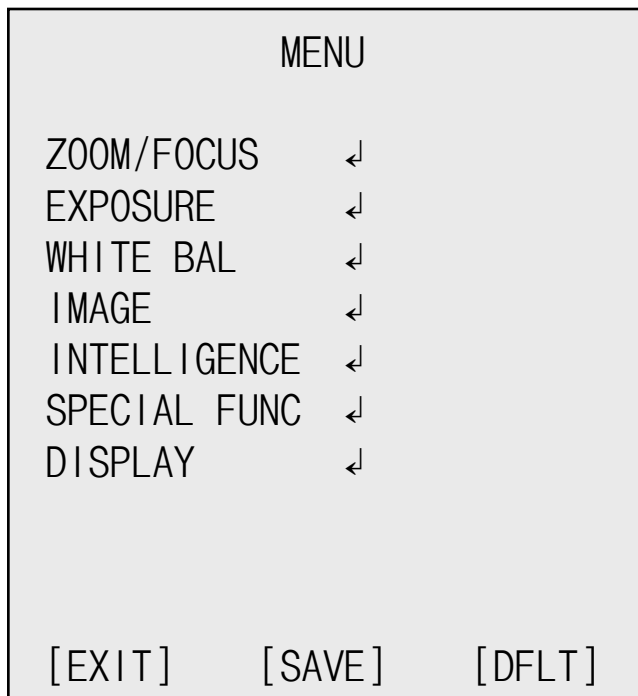

Functions can be setup using "Menu Key Command" of Visca protocol. The menu consists of the "Main Menu" and "Sub Menu". The main menu is displayed where 7 camera functions can be selected. To the push of each main menu selection, the sub-menu is displayed

If you want save the menu, select [SAVE].

If you want not save the menu, select [EXIT] (After select, Power off -> on)

If you want default the menu, select [DFLT]

 OSD Menu

## ◆ ZOOMFOCUS

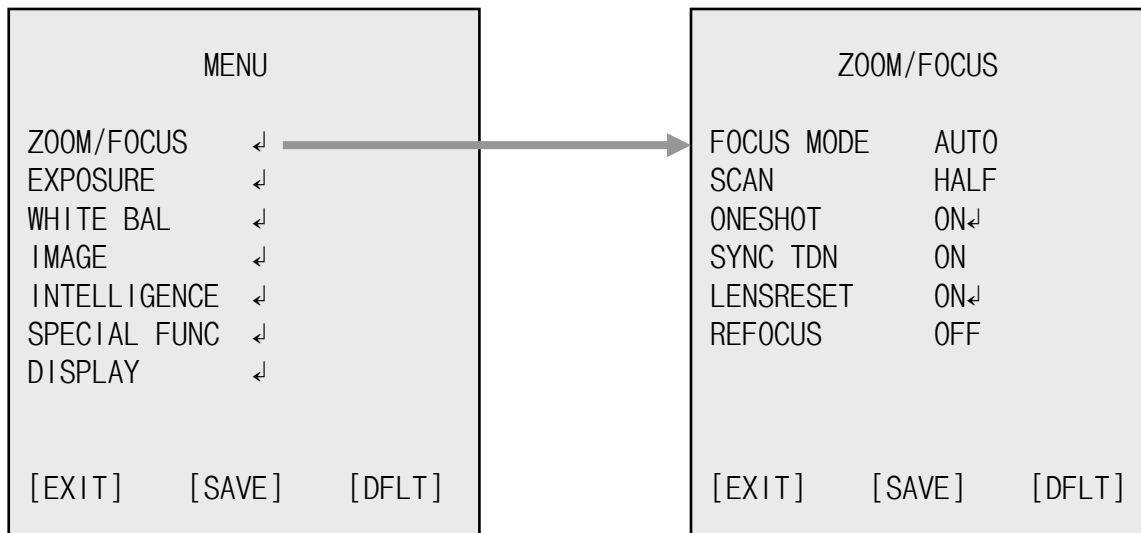

◆ FOCUS MODE : Select auto focus mode

- ▶ AUTO, MANUAL

◆ SCANNING : Select focus scan range

- ▶ HALF, FULL

◆ ONESHOT : Select readjust focus

- ▶ ON : Pressing the [SET] button more than 1 seconds activates the One-push Auto Focus.

◆ SYNC TDN : Select the One-shot AF when the switch TDN

- ▶ OFF, ON

◆ LENSRESET : Lens origin calibrated automatically

- ▶ ON : Pressing the [SET] button more than 1 seconds activates the Lens initialization.

◆ REFOCUS : select the refocus interval time

- ▶ OFF, 1day ~ 10days

**OSD Menu**

## ◆ EXPOSURE

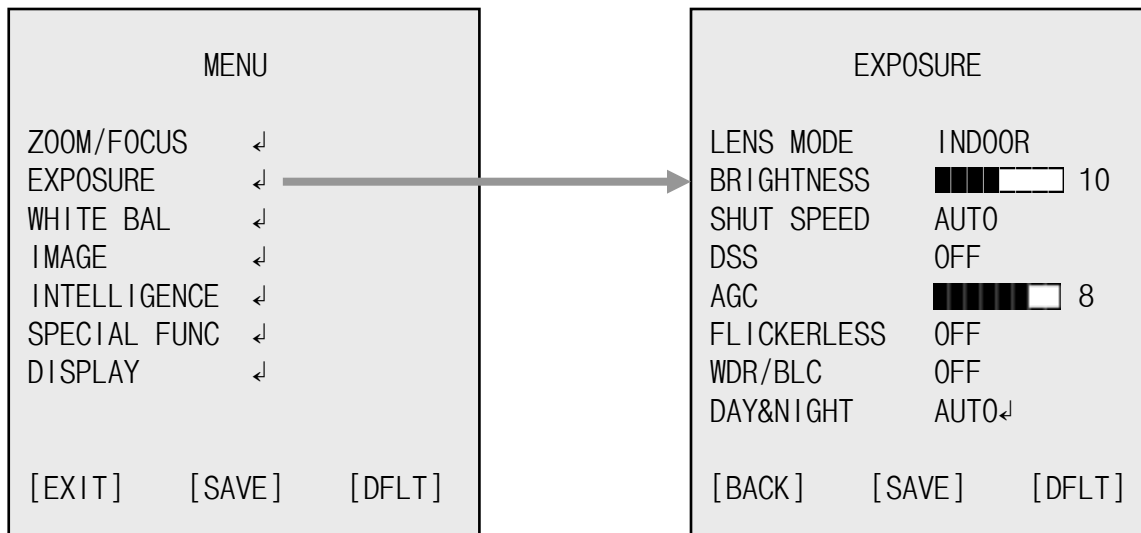

- ◆ LENS MODE : Select LENS mode
  - ▶ INDOOR / OUTDOOR / DEBLUR

- ◆ BRIGHTNESS : Adjust brightness level
  - ▶ 0(dark) ~ 20(bright) steps

- ◆ SHUT SPEED : Can be set in AUTO or MANUAL
  - ▶ AUTO / MANUAL↓

## ▷ Manual Shutter Speed

\* 60 / 50 fps mode

: x2, 1/60(50), 1/100, 1/120, 1/250, 1/500, 1/700, 1/1000, 1/2000, 1/3000, 1/6000, 1/10000, 1/20000, 1/30000, 1/60000 sec

\* 30 / 25 fps mode

: 1/30(25), 1/60(50), 1/100, 1/120, 1/250, 1/500, 1/700, 1/1000, 1/2000, 1/3000, 1/6000, 1/10000, 1/20000, 1/30000, 1/60000 sec

- ◆ DSS : Select maximum DSS(Digital Slow Shutter)

\* 60 / 50 fps mode

▶ OFF / x2, x4, x8, x16, x32, x64

\* 30 / 25 fps mode

▶ OFF / x2, x4, x8, x16, x32



 OSD Menu

- ◆ AGC : Select auto gain limit
  - ▶ 0 ~ 10 steps
- ◆ FLICKERLESS : Select Flickerless mode
  - ▶ OFF / ON (remove screen flicker)
- ◆ WDR/BLC : Select WDR(Wide Dynamic Range) or BLC(Back Light compensation)
  - ▶ WDR↓
    - ▷ MODE : Select WDR mode.
      - ▶ LINE, FRAME
    - ▷ LEVEL : Adjust WDR level.
      - ▶ LOW, MID-LOW, MIDDLE, MID-HIGH, HIGH
  - ※ WDR doesn't work in Shutter Manual Mode.
  - ▶ BLC↓
    - ▷ POSITION : Adjust the window position
    - ▷ SIZE : Adjust the window size
  - ※ Can't use WDR and BLC at the same time.  
(When WDR On, BLC is Off. And when BLC is On, WDR is Off)
- ◆ DAY&NIGHT : Select Day&Night
  - ▶ MODE : AUTO↓ / EXT-IN↓ / DAY / NIGHT↓
    - ▷ AUTO
      - ▶ DELAY : 0 ~ 255 sec
      - ▶ THRS : 0 ~ 28
        - Day→Night switching level in Auto Mode.
        - Switching in lower lux with higher threshold level.
      - ▶ GAP : LOW, MID-LOW, MIDDLE, MID-HIGH, HIGH
        - Margin between Day→Night switching level and Night→Day switching level.
      - ▶ IR DETECTION : Setting IR-Detection mode. (ON / OFF)
      - ▶ IR DET LEVEL : Setting IR-Detection level.
        - (LOW, MID-LOW, MIDDLE, MID-HIGH, HIGH)
      - ▶ ANTI-SAT : LED saturation improves. (0~20)
      - ▶ BURST : OFF / ON

**OSD Menu**

- ▷ EXT-IN
  - ▶ DELAY : 0 ~ 255 sec
  - ▶ ANTI-SAT : LED saturation improves. (0~20)
  - ▶ BURST : OFF / ON
  - ▶ POLARITY : External Input polarity (ACTIVE LOW / ACTIVE HIGH)
  
- ▷ NIGHT
  - ▶ ANTI-SAT : LED saturation improves. (0~20)
  - ▶ BURST : OFF / ON

深圳市凯莱锐电子科技有限公司

## OSD Menu

## ◆ WHITE BALANCE

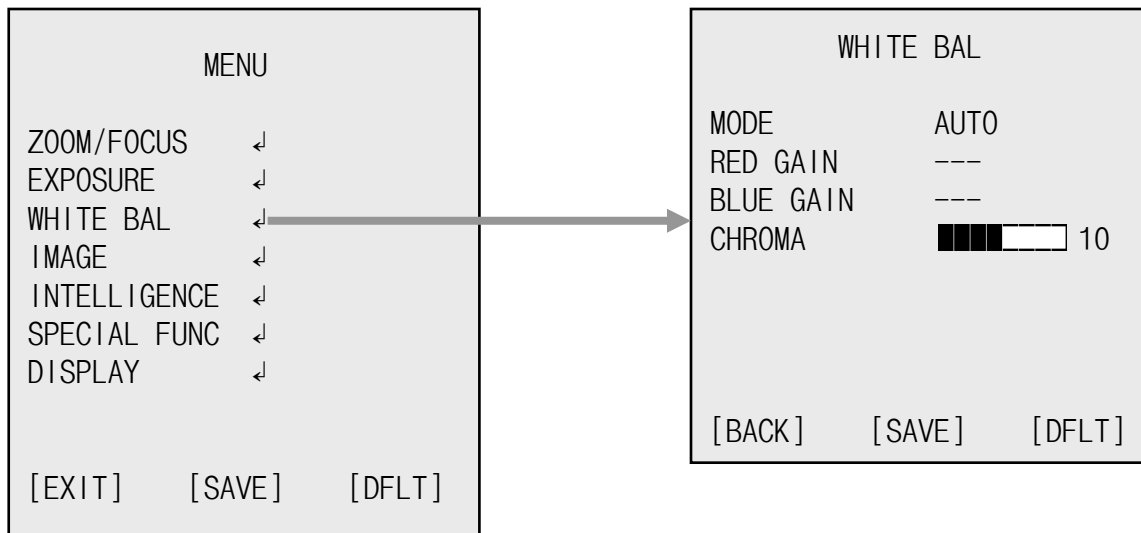

## ◆ AWB : Select WHITE BALANCE mode

## ▶ AUTO / ONE PUSH↓ / MANUAL / INDOOR / OUTDOOR / AUTO-EXT

- ▷ AUTO : Automatically adjusts color according to the available lighting.
- ▷ ONE PUSH : It is a fixed white balance mode that may be automatically readjusted only by pressing ONE PUSH
- ▷ MANUAL↓ : Color can be corrected when the user increases or decreases “RED GAIN” or “BLUE GAIN”.
- ▷ INDOOR : Set color temperature to be Indoor light (3700°K)
- ▷ OUTDOOR : Set color temperature to be Outdoor light (5100°K)
- ▷ AUTO-EXT : Auto mode operating on a wider range of color temperatures.

## ◆ RED GAIN : Adjust R gain value

- ▶ 0 ~ 20 steps

## ◆ BLUE GAIN : Adjust B gain value

- ▶ 0 ~ 20 steps

## ◆ CHROMA : Adjust CHROMA gain value

- ▶ 0 ~ 20 steps

## OSD Menu

## ◆ IMAGE

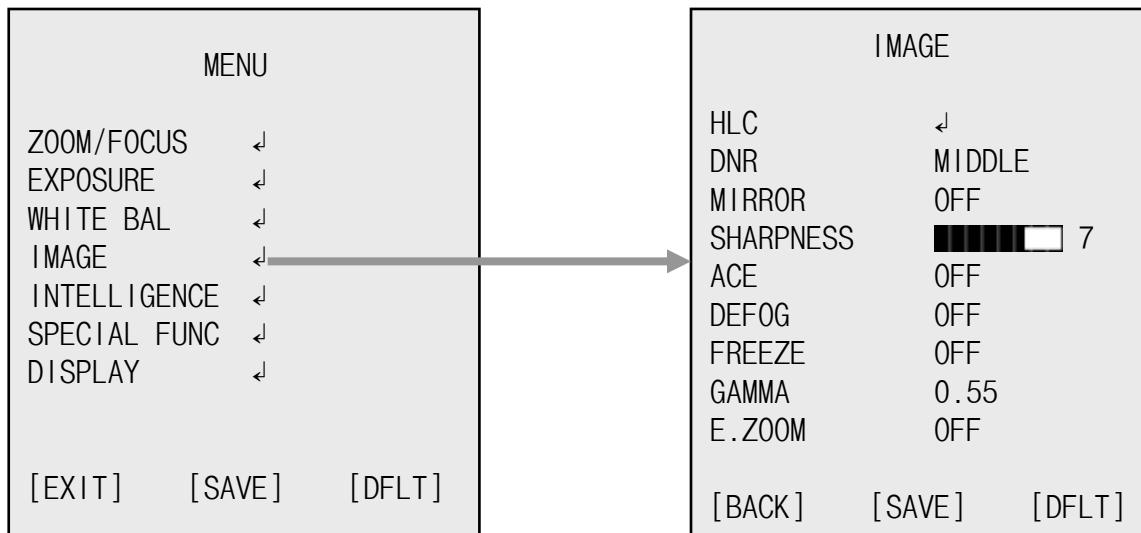

## ◆ HLC : Select High Light Compensation.

When extremely bright light is projected to the camera masking is used on the portion to prevent partial saturation on the monitor.

- ▷ MODE : OFF / ON / NIGHT
- ▷ LEVEL : 0 ~ 20 steps
- ▷ COLOR : 0 ~ 13 steps

## ◆ DNR : Select Digital Noise Reduction

- ▶ OFF / LOW / MIDDLE / HIGH / AUTO

## ◆ MIRROR : Select a flip mode

- ▶ OFF / H / V / H&V
- ▷ H : You can flip the picture horizontally on the screen
- ▷ V : You can flip the picture vertically on the screen
- ▷ H&V : You can flip the picture horizontally & vertically on the screen

## ◆ SHARPNESS : Adjust sharpness level

- ▶ 0 ~ 10 steps

## ◆ ACE : Select Digital WDR (Wide Dynamic Range)

- ▶ OFF / LOW / MIDDLE / HIGH

**OSD Menu**

- ◆ DEFOG : Carry out defog function
  - ▶ OFF / ON↓
    - ▷ MODE : AUTO / MANUAL
    - ▷ LEVEL : LOW / MIDDLE / HIGH
  
- ※ Can't use DEFOG and ACE at the same time  
(When ACE On, DEFOG is Off. And when DEFOG is On, ACE is Off)
  
- ◆ Freeze : Select real or still mode
  - ▶ OFF / ON
  
- ◆ GAMMA : Select GAMMA
  - ▶ 0.45 / 0.55 / 0.65 / 0.75
  
- ◆ E.ZOOM
  - ▶ OFF / ON↓
    - ▷ LIMIT : Max x2 ~ x19, x21, x23, x25, x28, x32
    - ▷ POSITION : Select maximum digital zoom magnification.

深圳市凯莱锐电子科技有限公司

## OSD Menu

## ◆ INTELLIGENCE

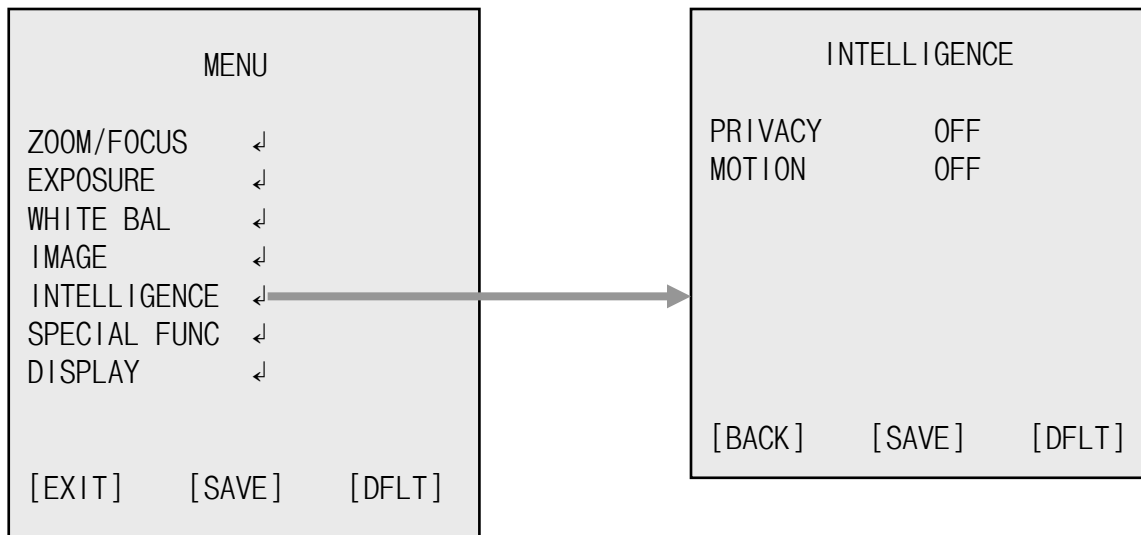

## ◆ PRIVACY : Hide an area you want to hide on the screen

## ▶ OFF / ON↓

- ▷ MASK# : Select mask area number (1 ~ 24)
- ▷ MODE : Mask enable or disable (OFF / ON)
- ▷ POSITION : Adjust the mask position
- ▷ SIZE : Adjust the mask size
- ▷ COLOR : Select mask color (0 ~ 13)
- ▷ TRANS : Select mask transparency level (0 ~ 3)

## ◆ MOTION : When there is movement of the subject in the screen, there will be an motion detection

## ▶ OFF / ON↓

- ▷ AREA# : Setting 3 areas(1~3) of motion detection
- ▷ MODE : OFF / ON (Limit and define areas of motion detection)
- ▷ SENSITIVITY : Adjust sensitivity of MD (0 ~ 20 steps)  
More sensitive to setting to low step with sensitivity
- ▷ POSITION : Adjust the Area position
- ▷ SIZE : Adjust the Area size
- ▷ INTERVAL TIME : Select the alarm interval time (0 ~ 255sec)
- ▷ DWELL TIME : Select the duration time about changing MD mode  
(0 ~ 255sec)

## OSD Menu

## ◆ SPECIAL FUNC

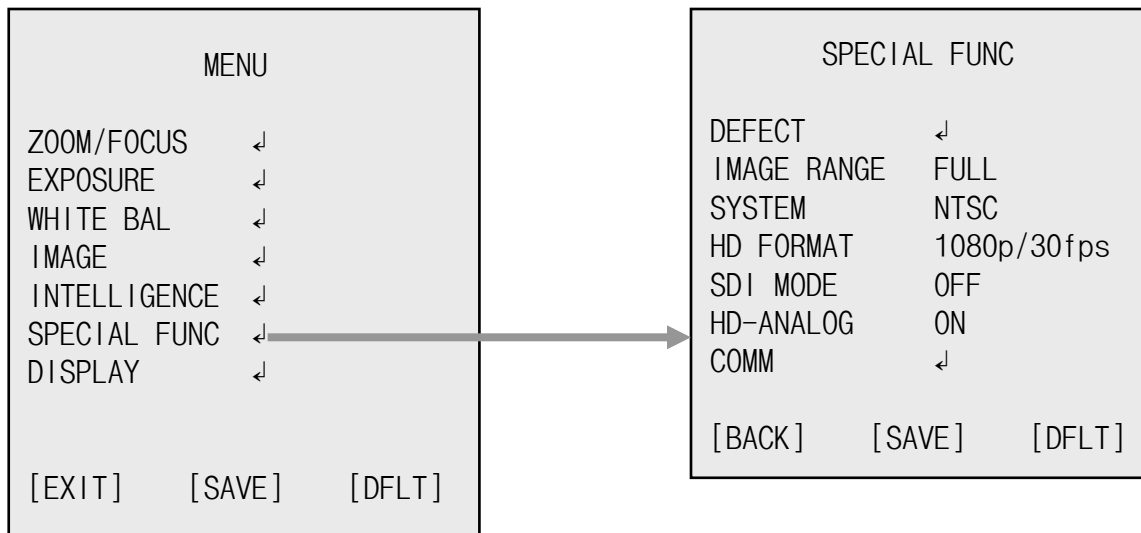

- ◆ DEFECT : Compensates for bad pixels that may occur. Occurs when the whole screen is in full black or if there is bad pixelation and it changes the THRS values until the screen is fixed.
- ◆ IMAGE RANGE : Select image bit range. (Full : 100%, Compressed : 75%)
  - ▶ FULL, COMP, USER↓
  - ▷ LEVEL : Select user mode level (0 ~ 32)
- ◆ SYSTEM : Select NTSC(30/60fps) or PAL(25/50fps).
- ◆ HD FORMAT : Select Digital output
  - ▶ 1080i/60(50)fps, 1080p/60(50)fps, 1080p/30(25)fps, 720p/30(25)fps, 720p/60(50)fps
- ◆ SDI MODE : Select SDI mode
  - ▶ OFF / HD-SDI / EX-SDI 135M (v2.0) / EX-SDI 135M+ (v2.1) / EX-SDI 270M (v1.0)
- ◆ HD-ANALOG : Select analog output mode
  - ▶ OFF / CVBS / HD-T
- ※ When HD-T On, you can't select 1080p/60(50)fps mode

**OSD Menu**

- ◆ COMM : Set up the camera ID, baud rate, protocol
  - ▷ ID : Select the camera ID
    - ▶ 1 ~ 255
  - ▷ BAUD RATE : Select serial communication speed
    - ▶ 2400 / 4800 / 9600 / 19200 / 38400 / 57600 / 115200bps
  - ▷ PROTOCOL : Select operating protocol
    - ▶ VISCA / PELCO-D / PELCO-P / UPDATE
  - ▷ UTC : Select HD-Analog UTC function
    - ▶ OFF / ON
  - ▷ UTC FORWARD : Sends the UTC command to Controller via UART .
    - ▶ OFF / ON

深圳市凯莱锐电子科技有限公司



**OSD Menu**

◆ **DISPLAY**

MENU	
ZOOM/FOCUS	↓
EXPOSURE	↓
WHITE BAL	↓
IMAGE	↓
INTELLIGENCE	↓
SPECIAL FUNC	↓
DISPLAY	↓
[EXIT]	[SAVE] [DFLT]

DISPLAY	
DISP SEL	ON↓
SET TITLE	↓
INIT SEL	ON ↓
SET INIT MSG	↓
LANGUAGE	ENGLISH
[BACK]	[SAVE] [DFLT]

◆ **DISP SEL** : Select display item.

▶ OFF / ON↓

▷ ID : OFF / ON

▷ TITLE : OFF / ON

▷ ZOOM RATIO : OFF / ON

▷ SYSTEM MSG : OFF / ON (MD Alarm and Wait message)

◆ **SET TITLE** : Select camera title menu (Text edit- max 40 characters)

◆ **INIT SEL** : Select display initial message.

▶ OFF / ON↓

▷ ID : OFF / ON

▷ BAUDRATE : OFF / ON

▷ PROTOCOL : OFF / ON

▷ VERSION : OFF / ON

▷ INIT MSG : OFF / ON

◆ **SET INIT MSG** : modify initial message. (Text edit - max 40 characters)

◆ **LANGUAGE** : Select language.

▶ English / Simplified Chinese / Traditional Chinese / Japanese

※ **Character Table of Text edit Mode**

A B C D E F G H I J K L M N O P Q R S T

U V W X Y Z a b c d e f g h i j k l m n

o p q r s t u v w x y z , . ( ) { } [ ]

0 1 2 3 4 5 6 7 8 9 \* + - / = ~ ! ? " "

Drawing

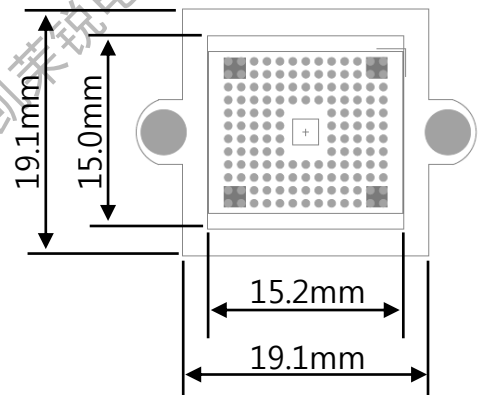
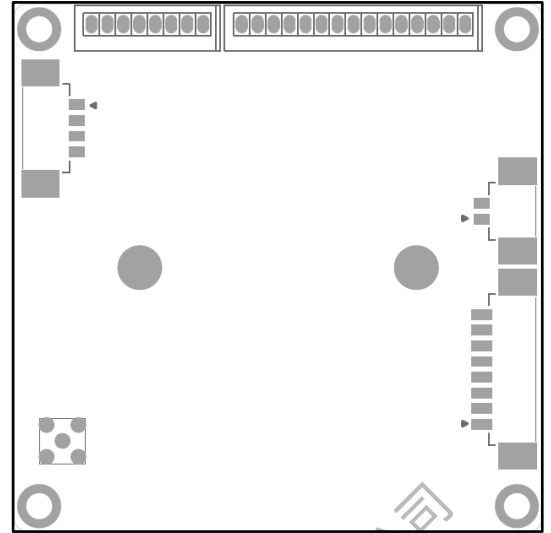
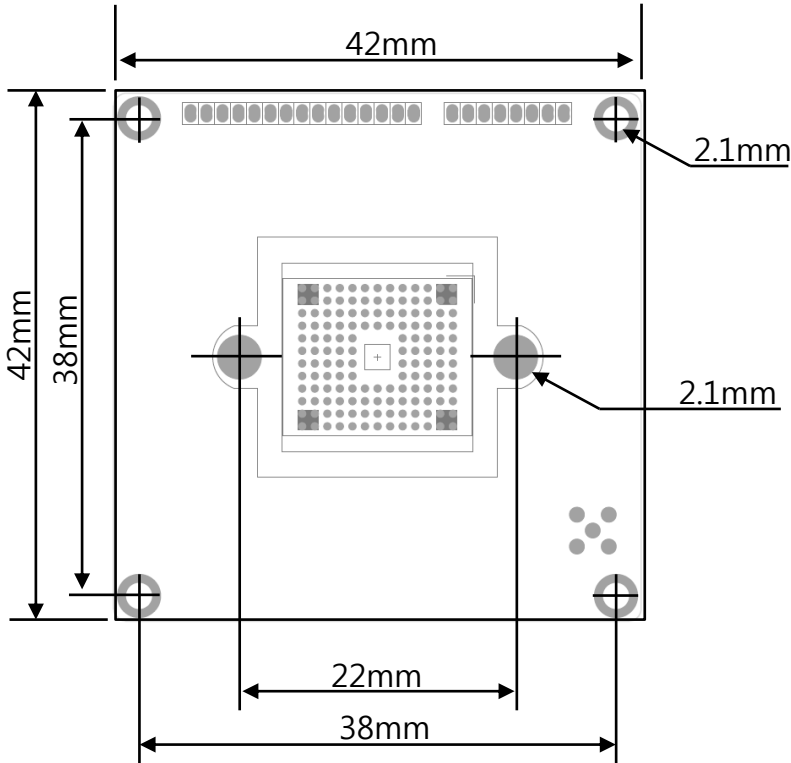

深圳市凯莱锐电子科技有限公司